

## Performance Evaluation of a Developed Maize Sheller

T.M. Azeez<sup>1\*</sup>, I.D. Uchegbu<sup>1</sup>, S.A. Babalola<sup>1</sup>, O.O. Odediran<sup>1</sup>

<sup>1</sup> Department of Mechanical and Mechatronics Engineering, Afe Babalola University, Ado Ekiti, Nigeria

\*Corresponding author: T.M. Azeez, E-mail: [Azeeztemitayo221@abuad.edu.ng](mailto:Azeeztemitayo221@abuad.edu.ng)

Received: June 25, 2017, Accepted: August 31, 2017, Published: August 31, 2017.

### ABSTRACT

Assessing the performance characteristics of the developed maize shelling machine is the focus of this paper. Maize shelling machine was fabricated based on engineering design approach with the aid of software (CAD) and values, and was later fabricated at Afe Babalola University Ado Ekiti Central Workshop using suitable materials after considering the factors such as Hardness, ease of machining, tensile strength, availability, durability and the cost. The machine is electrically operated by an electric motor with power rating of 2.235 kW, speed of 1430 rpm and torque of 14.92 Nm. Kernel losses and damages were found to be very negligible. It shells 60 times as fast as hand shelling. The design presented in this paper is aided with computer software (Autodesk Inventor) to give the accurate and precise results. Maize shelling machine was developed to shell maize and separate the cob from the grains with appropriate engineering design factors. The efficiency of the machine is a benchmarked against the commercially available maize shelling machines. It has an average shelling capacity of 55 kg/hr, its shelling efficiency is 91.29 % and breakage is very insignificant, as well as losses. The machine can help to substantially reduce the human labor and stress involved in shelling maize and also reducing the time used for shelling operation on farms. There is no doubt that the machine will ease the long term problem of maize shelling especially for the rural farmers.

**Keywords:** *Maize, Shelling, Machine, Design, Development*

### INTRODUCTION

Shelling of maize to remove the grain from the cob has been a time consuming, tedious and a mind cracking process especially to the many small scale farmers in the country who basically practice subsistence maize farming. However, traditional shelling methods do not support large-scale shelling of maize, especially for commercial purposes. Hand shelling takes a lot of time, even with some hand operated simple tools. Few researchers reported that tractor PTO (power take off) shaft operated are the most common mechanized shellers that are designed for maize threshing or shelling [1].

The invention of the modern crank-operated maize sheller is widely attributed to Lester E. Denison from Middlesex County, Connecticut [2]. A patent was issued for a freestanding, hand-operated machine that removed individual kernels of maize by pulling the cob through a series of metal-toothed cylinders which stripped the kernels off the cob [2]. During that same century, dozens of American patents were filed for maize shellers made of wood, iron or a combination of the two, including one in 1845 by Joseph Briggs of Saratoga County, New York [2]. His Sheller produced similar results to that of the Denison Sheller but was a compact unit, designed to be supported on a bench or chair.

In the early 1900's, a number of engine-powered maize shellers were developed which provided the foundation for modern commercial and agricultural shellers and a good example is the buch-2-hole antique shellers [3]. These large stream-powered

machines have now been mostly replaced with the use of the modern combine harvester that strips the kernels from the maize cob while the maize is being harvested in the field [1]. Since the introduction of the modern maize sheller in the 1800's, the basic design and function of this machine has remained the same with most modern-day maize shellers bearing a strong resemblance to the original models designed by inventors like Denison and Briggs [4].

The tractor PTO (power take off) shaft operated shellers are equipped with rotating threshing drum with beaters or teeth, which cause damages to the seed. The tractors can cause great damage to the maize seeds i.e. breaking the cob to pieces). Besides, the cost of purchasing such shellers are high for the rural farmer and as a result of all these, it will be difficult for the rural farmers to maximize profits on their produce therefore the need for a relatively low cost maize shelling mechanism that will be affordable to the farmers not only to meet their shelling requirement but also to improve the threshing efficiency and reduce damage to the seed [1].

### MATERIALS AND METHODS

Consideration for material selection was based on availability, ease of machining, durability, strength, cost, mechanical and chemical properties. Table 1 shows the parts of the machine as well as the material selected for each part.

Table1: Parts of a developed maize shelling machine and its material

S/N	Components	Functions	Material
1.	Hopper	Serves as storage for the maize to move into the crushing chamber.	Mild steel
2.	Crusher	To shell and give out grains.	Mild steel
3.	Shaft	It transmits torque and motion from the pulley to turn the crusher.	Mild steel
4.	Pillow Bearing	It holds the bearing into position.	Cast iron

5.	Stand	It allows the body to rest on firmly and absorbed vibration.	Angle bar Mild Steel
6.	Pulley	It transmits the torque from the electric motor to the Shaft.	Cast iron
7.	Electric Motor	To generate a torque for the system.	2.234 kW, speed of 1430 rpm
8.	Bearing	To allow free movement of the shaft.	Cast iron
9.	V-Belt	To transmit the torque from the electric motor to the pulley.	Fabric cord

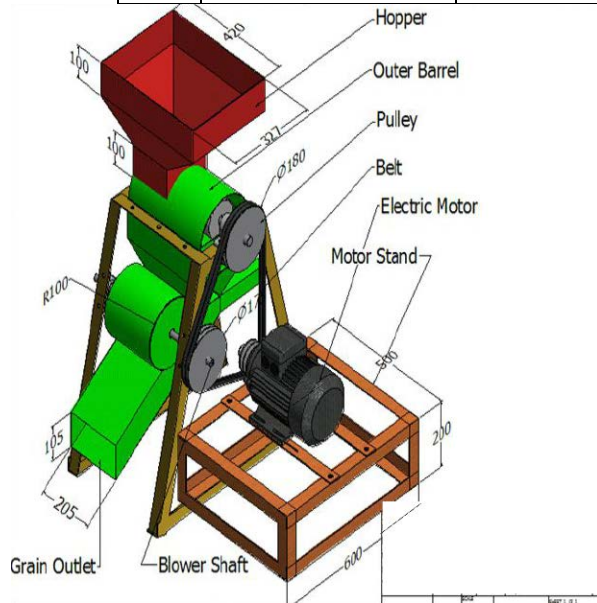

$$N = 1430 \text{ rpm}$$

$$\omega = \frac{2 \times \pi \times 1430}{60}$$

$$\omega = 149.74 \text{ rad/sec}$$

Torque T is given as

$$T = m \times a \times r \quad (4)$$

Given that m is mass of the threshing bar in **Kg** (6.1), a is the acceleration due to gravity in  $\text{m/s}^2$  (9.81) and r = radial distance in m (0.25).

From equation (3.4)

$$T = 6.1 \times 9.81 \times 0.25$$

$$T = 14.92 \text{ Nm}$$

From equation (3)

$$P = T \times \omega$$

Therefore,

$$\text{Power} = 14.92 \times 149.74$$

$$P = 2234.120 \text{ W} = 2.234 \text{ kW}$$

Figure 1- Assembled design of a maize sheller

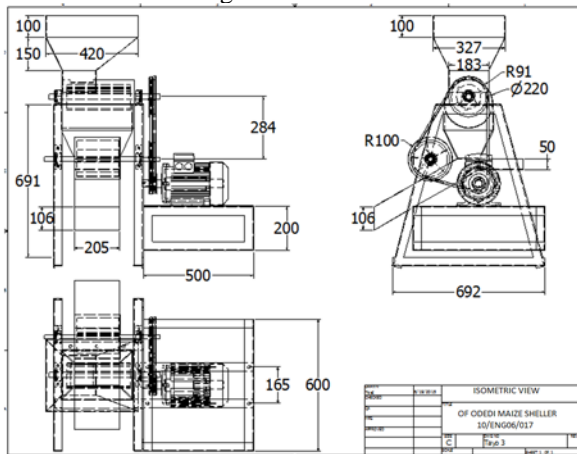

Figure 2- Isometric view of a maize sheller

## DESIGN CALCULATION

### The Power Requirement

The rating was determined by calculation results. Power transmitted by shaft, angular speed and torque was determined using equation 1, 2 and 3 respectively.

$$P = \frac{2\pi N}{60} \times T \quad (1)$$

$$\omega = \frac{2\pi N}{60} \quad (2)$$

$$P = T \times \omega \quad (3)$$

The speed for high and efficient threshing output was given by the AUTODESK inventor software as **1430 rpm**.

Three phase motor of power 2.235 **kW** electric motor with the speed of **1430 rpm** was chosen under the required load conditions and a corresponding torque is of **14.31 Nm** has computed by the Autodesk Inventor Software. This speed was used as the basis for the calculation. Where:

The volume of hopper,  $V = 0.00392 \text{ m}^3$ ;

Overall height,  $H = 0.335 \text{ m}$ ;

Acceleration due to gravity =  $9.81 \text{ m/s}^2$

Angular velocity,  $\omega = 149.74 \text{ rad/sec}$ ;

The safe load is (Approx 15 Kg) =  $150 \text{ N}$ ;

Torque =  $14.92 \text{ Nm}$ ;

Power delivered by shaft =  $2.235 \text{ kW}$ ;

Prime mover (electric motor) =  $3 \text{ Hp}$ .

### Shaft Design

The Autodesk shaft generation software (Autodesk Inventor, 2010) was used to test the reliability of the shaft diameter under required loads condition. In this design, diameter 25 mm, length 500 mm for threshing shaft and 20 mm, length 500 mm for blower/fan were generated via the software which serves the interests of achieving the overall machine workability and also lower the costs of materials. The shaft has a key way and with the specified dimensions to firmly hold in place the pulley.

### Design of a Key

The width of a key is made one-quarter the diameter of the shaft. The length of the key was calculated as

$$L = \pi d/2 = 1.57d \quad (6)$$

The forces on the top and bottom of the key resist tipping of the key, and the force,  $F$ , between the side of the key and the key

way in the hub is due to the resisting torque,  $T'$ :  
 $T' = Fd/2 = FL/\pi$  (7)

Where,  $T'$  the resisting torque,  $F$  is the resisting force,  $d$  is the diameter of shaft and  $L$  is the length of key.

**Pulley Design**

V-belts are made of fabric, cords and are molded in rubber while the pulleys are made of cast iron in order to reduce the overall weight of machine.

The ratio between the velocities of the driver and the driven pulley is given as;

$$\frac{N_2}{N_1} = \frac{d_1}{d_2}$$
 (8)

Where;  $d_1$  is the diameter of the driver pulley in mm,  $d_2$  is diameter of the driven pulley in mm,  $N_1$  is the speed of the driver in rpm and  $N_2$  is the speed of the driven in rpm.

The length that passes over the driver in one minute is given as

$$L_1 = \pi d_1 N_1$$
 (9)

Similarly, the length that passes over the driven in one minute is

$$L_2 = \pi d_2 N_2$$
 (10)

The diameters of the pulleys are 85 mm, 180 mm and 175 mm for the motor shaft, threshing arm and blower respectively.

**Performance Evaluation of maize shelling machine**

Maize Sheller was subjected to test and it was found to shell maize very effectively. The following parameters were determined from the data collected:

- Capacity (rate of shelling) =  $\frac{\text{mass shelled grains} \times 3600 \text{ kg/hr}}{\text{time taken (s)}}$
- Shelling Efficiency =  $\frac{\text{mass of shelled grains}}{\text{total mass of grains (shelled+unshelled)}} \times 100$
- Grain damage =  $\frac{\text{mass of damage grain}}{\text{mass of shelled grains}} \times 100$

Maize samples were taken and the average mass of maize measured is 0.250 kg. Samples were carried out in 3 trials.

**RESULTS AND DISCUSSIONS**

**Capacity (rate of shelling)**

Table 2: Shelling capacity with the use of developed machine

Trial	Mass of grain(kg)	Time taken(s)	Rate of shelling expression(kg/hr)	Rate of Shelling(kg/hr)
1	0.202	12	$\frac{0.202 \times 3600}{12}$	60.6
2	0.436	32	$\frac{0.436 \times 3600}{32}$	49
3	0.262	17	$\frac{0.262 \times 3600}{17}$	1.75

Table 3: Shelling capacity with the use of hand

Trial	Mass of grain(kg)	Time taken(s)	Rate of shelling expression(kg/hr)	Rate of Shelling(kg/hr)
1	0.196	460.2	$\frac{0.19 \times 3600 \text{ kg/hr}}{460.2}$	1.53
2	0.400	800.6	$\frac{0.400 \times 3600}{800.6}$	1.79
3	0.255	512.4	$\frac{0.255 \times 3600}{512.4}$	1.75

Table 4: Comparison of the two shelling methods

Trails	Maize Sheller			Hand Shelling		
	Time (s)	Mass of shelled grains (kg)	Output (kg/hr)	Time (s)	Mass of shelled grains (kg)	Output (kg/hr)
1	12	0.202	60.6	460.2	0.196	1.53
2	32	0.436	49.0	800.6	0.400	1.79
3	17	0.262	55.4	512.4	0.255	1.75
Mean			55.0			1.69

Table 5: Shelling efficiency

Trial	Mass of shelled grain(kg)	Mass of unshelled grain(kg)	Total mass of grain (kg)	Shelling efficiency	Shelling efficiency (%)

1	1.234	0.065	1.299	$\frac{1.234}{1.299} \times 100$	94.97
2	0.260	0.020	0.280	$\frac{0.260}{0.280} \times 100$	92.8
3	0.436	0.070	0.506	$\frac{0.436}{0.506} \times 100$	86.1

## Grain damage

Table 6: Grain damage with the use of developed maize sheller

Trials	Mass of shelled grains(kg)	Mass of damage grains(kg)	Percentage of damaged grains %
1	1.23	0.08	0.06
2	0.26	0.04	0.15
3	0.20	0.03	0.15

## DISCUSSION

The shelling capacity shown in table 2 and table 3 indicated that there is decrease in hand shelling which increases in machine shelling an advantage over the hand shelling in terms of shelling capacity (output). The mean shelling efficiency obtained as 91.29 % as shown in table 5, with an average shelling capacity of 55 kg/hr as shown in table 4. Table 6 shows the grain damage with the use hand machine and was discovered that it was so negligible with the ranging value 0.03kg to 0.26kg

The machine has a unique feature which will permit the belt to be adjusted to suit to specific prerequisites or bring into a fitting connection which will prevent slacking and cutting of the belt which will lessen the expenses subsequently bringing about higher productivity. The machine is also detachable so as to make assembling and disassembling easy, also to help detect faults and fix them quickly. Maintenance on the machine will be carried out easily and down time will be reduced in other to increase machine efficiency.

## CONCLUSION

A simple, efficient, less tedious machine for shelling maize has been developed. Materials used in fabricating the machine are affordable and locally available.

ODEDI maize shelling machine can shell maize of various sizes and has a shelling efficiency is 91.29 % and minimal 0.12 % grain damage with an average shelling capacity of 55 kg/hr. The machine operates smoothly and efficiently when in operation. The shelled grains flow freely through the grain outlet, the chaffs

are being blown off in opposite direction by the blower while the cobs are discharged easily through the cob outlet. It is less bulky and the ergonomic considerations in the design would allow for its comfortable use in a standing posture for it can easily be operated by either male or female subjects.

The machine can help to substantially reduce the human labor and stress involved in shelling maize at an affordable cost and also reduces the time used for shelling operation on big and small farms. There is no doubt that the machine will ease the long term problem of maize shelling especially for the rural farmers.

## REFERENCES

1. Analysis and performance of fibre Composites, B. D. Agarwal and L..
1. J. Broutman Wiley- Interscience, New York, 1980.
2. Mechanics of Composite Materials, (Mechanical Engineering), Autar K. Kaw, 2/e, CRC Pubi.
3. Composite Materials Science and Engineering, Kishan K. Chawla, Springer, 2009
4. Analysis of Laminated Composite Structures, L.R. Calcote, Van Nostrand Rainfold, New York, 1969.
5. Machanics of Composite Materials and Structures, madhujit Mukhpadhyay, New York, 1969.
6. Finite Element Analysis of Composite Materials, Ever J. Barbero, CRC Press, 2077
7. Engineering Mechanics of Composite Materials- Isaac and M Daniel, Oxford Univ. Press, 1994.
8. Mechanics of Composite Materials, R. M. Jones, Mc Graw Hill Company, NewYork, 1975.

**Citation:** T.M. Azeez *et al.* (2017) Performance Evaluation of a Developed Maize Sheller, J. of Advancement in Engineering and Technology, V5I2.02. DOI: 10.5281/zenodo.1000030.

**Copyright:** © 2017 T.M. Azeez. This is an open-access article distributed under the terms of the Creative Commons Attribution License, which permits unrestricted use, distribution, and reproduction in any medium, provided the original author and source are credited